

Course: 3D Design
Title: Dice
Dropbox File:
Blender: Version 2.5X
Level: Beginning
Author: Neal Hirsig (nhirsig@tufts.edu)
July 11, 2010

Dice

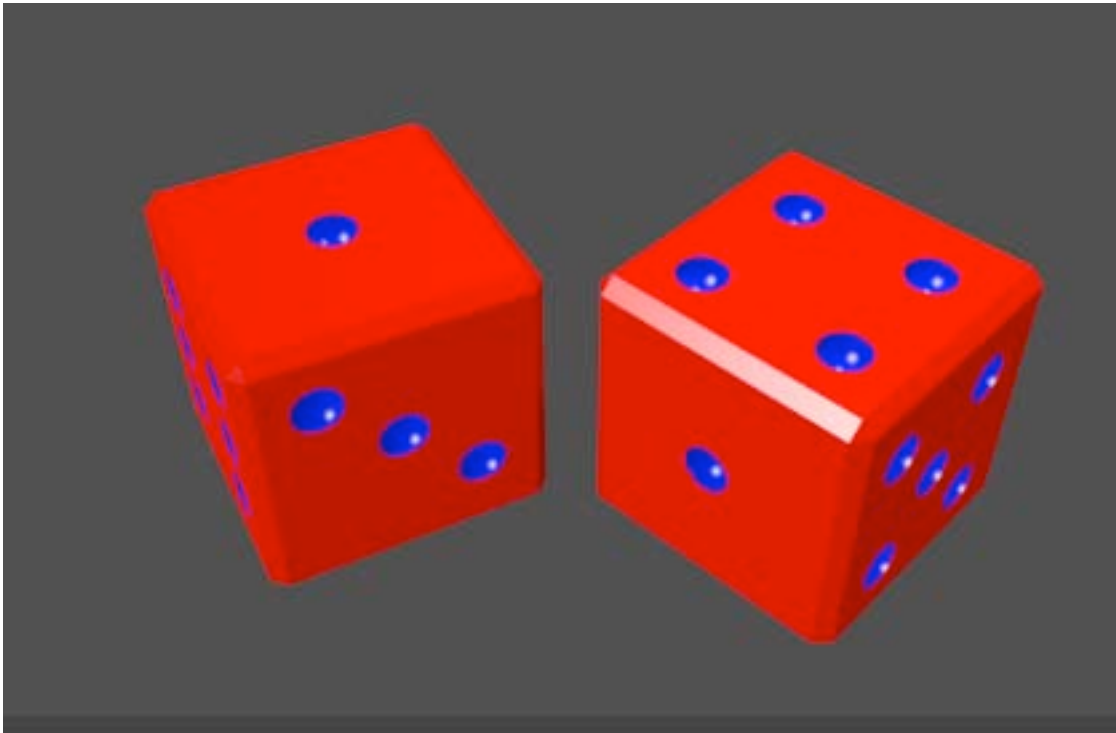

In this tutorial, we'll create a pair of dice in Blender using a Boolean Operation.

A completed copy of this tutorial named DiceComplete.blend is located on our course site.

Open a default Blender file.

We will use the default cube object for this tutorial. We want the die to beveled edges. With the cube selected, press the Modifier context button in the Properties panel. Add a Bevel modifier to the cube. Set the bevel width to .1

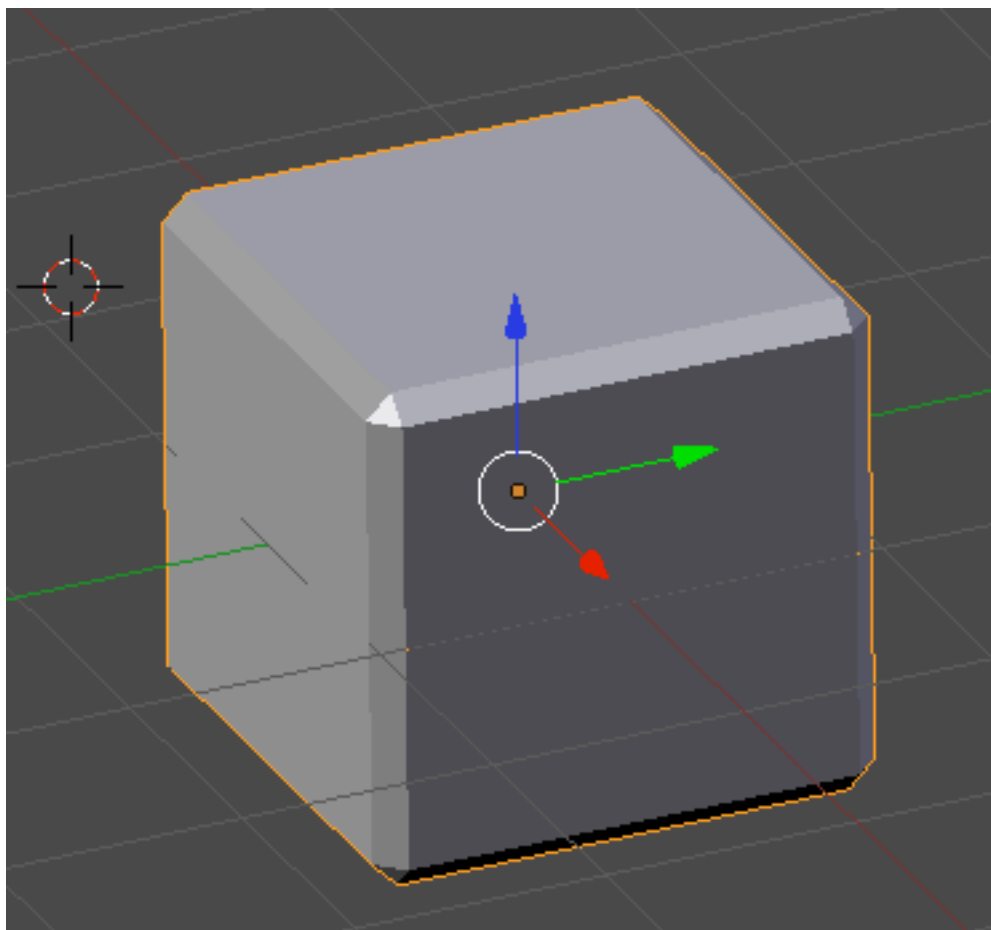
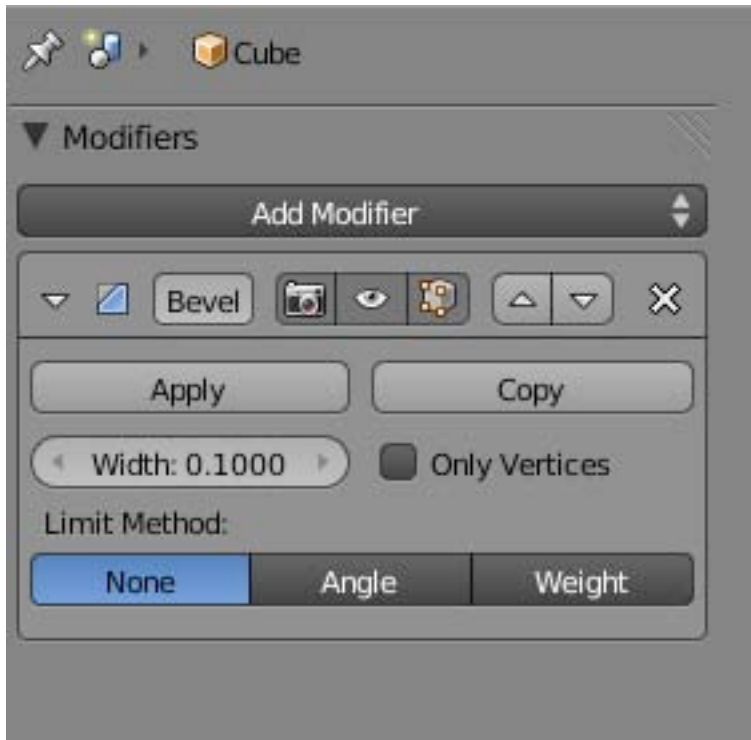

Next, **click on the apply button** in the bevel modifier panel. This will permanently apply the bevel modifier to the mesh.

TAB into edit mode.

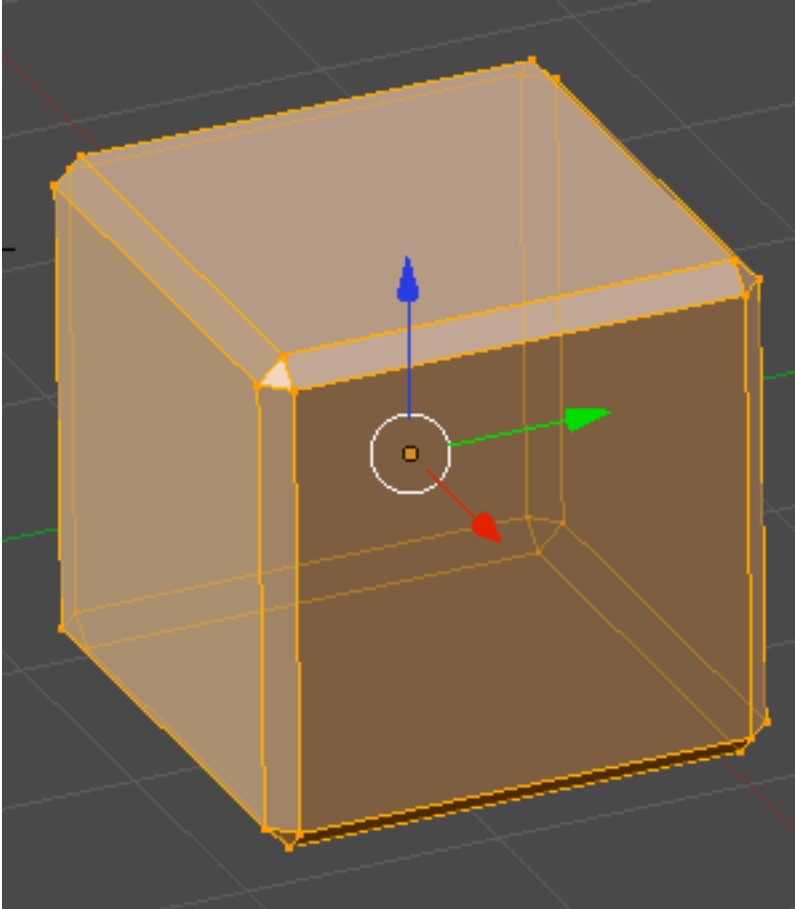

Press CTRL-TAB and go to face select mode. Select the 6 large faces and press the subdivide button located on the 3D editor tools panel 4 times.

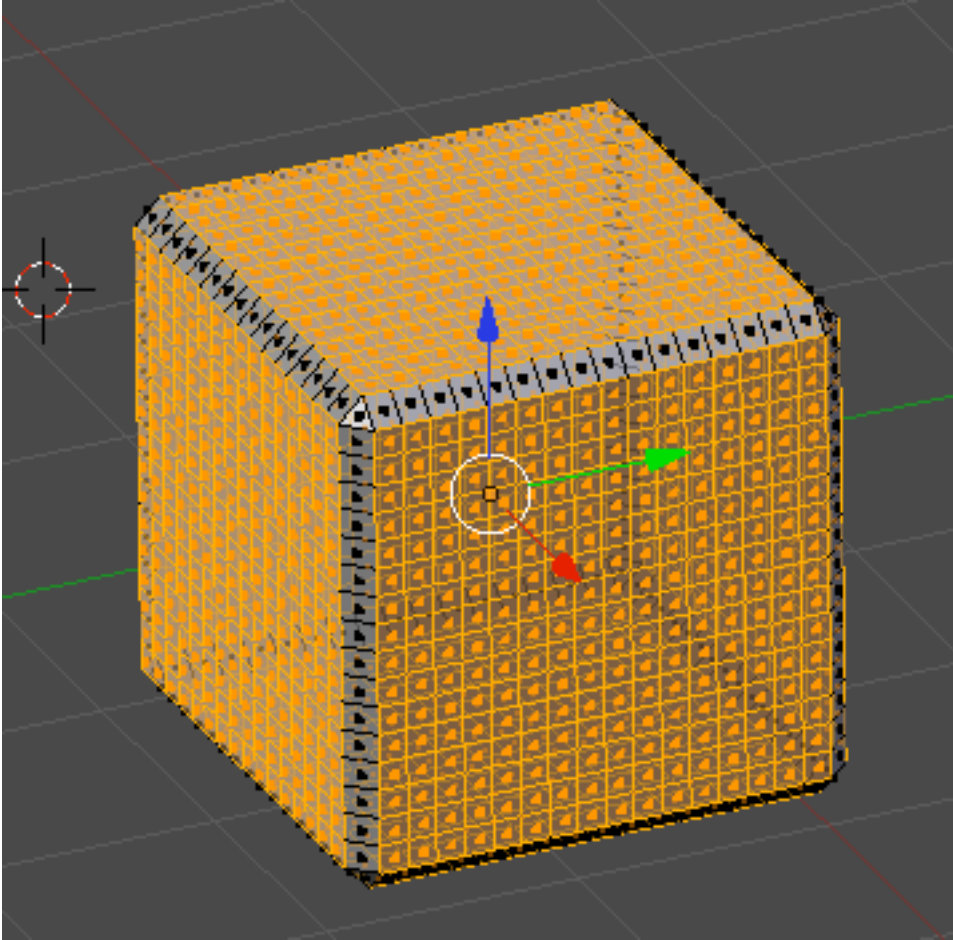

This will create many vertices on each face of the cube object, which we will need later in the Boolean operation.

In this tutorial we will be using a Boolean operation, which will subtract areas of the cube to form the indentations (dots) on a die.

TAB out of edit mode. Name this object “Die1”. With the Die1 object selected, press the Materials context button located on the properties panel. Add a new material. Name the material “Red”.

Click on the diffuse color swatch and make it a red color (R=1, G=0, B=0).

Set the specular intensity to .75 and the hardness to 255. This will give the die a more plastic appearance.

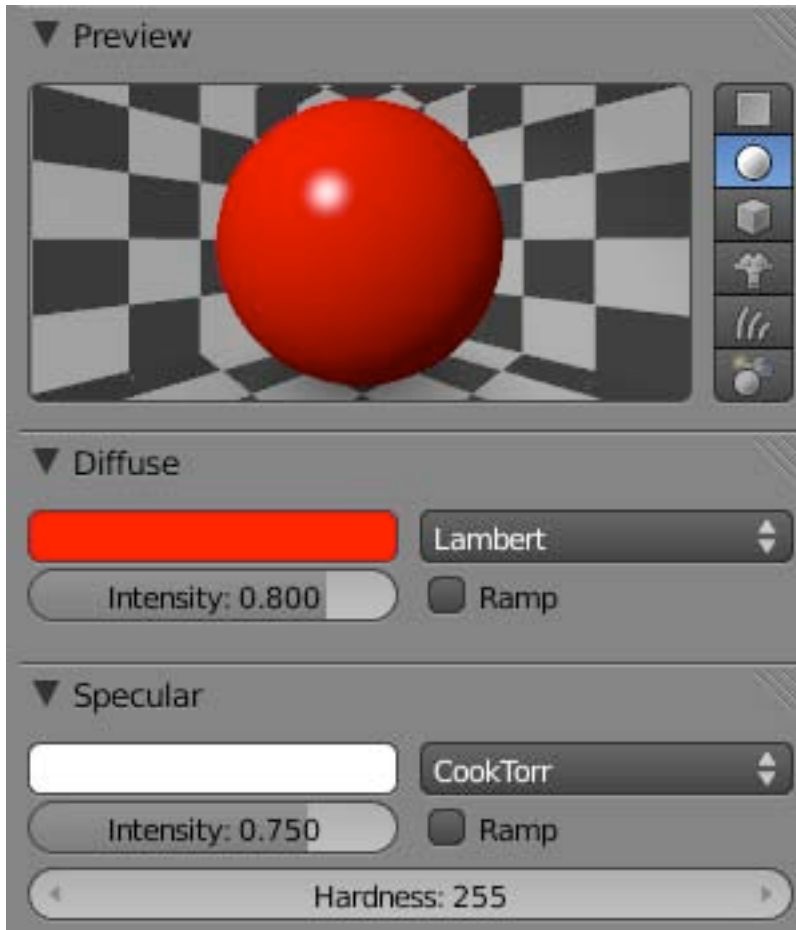

Go to top view. Place your 3D cursor somewhere above the die1 object and add a UV sphere object.

Scale the sphere object down as shown below.

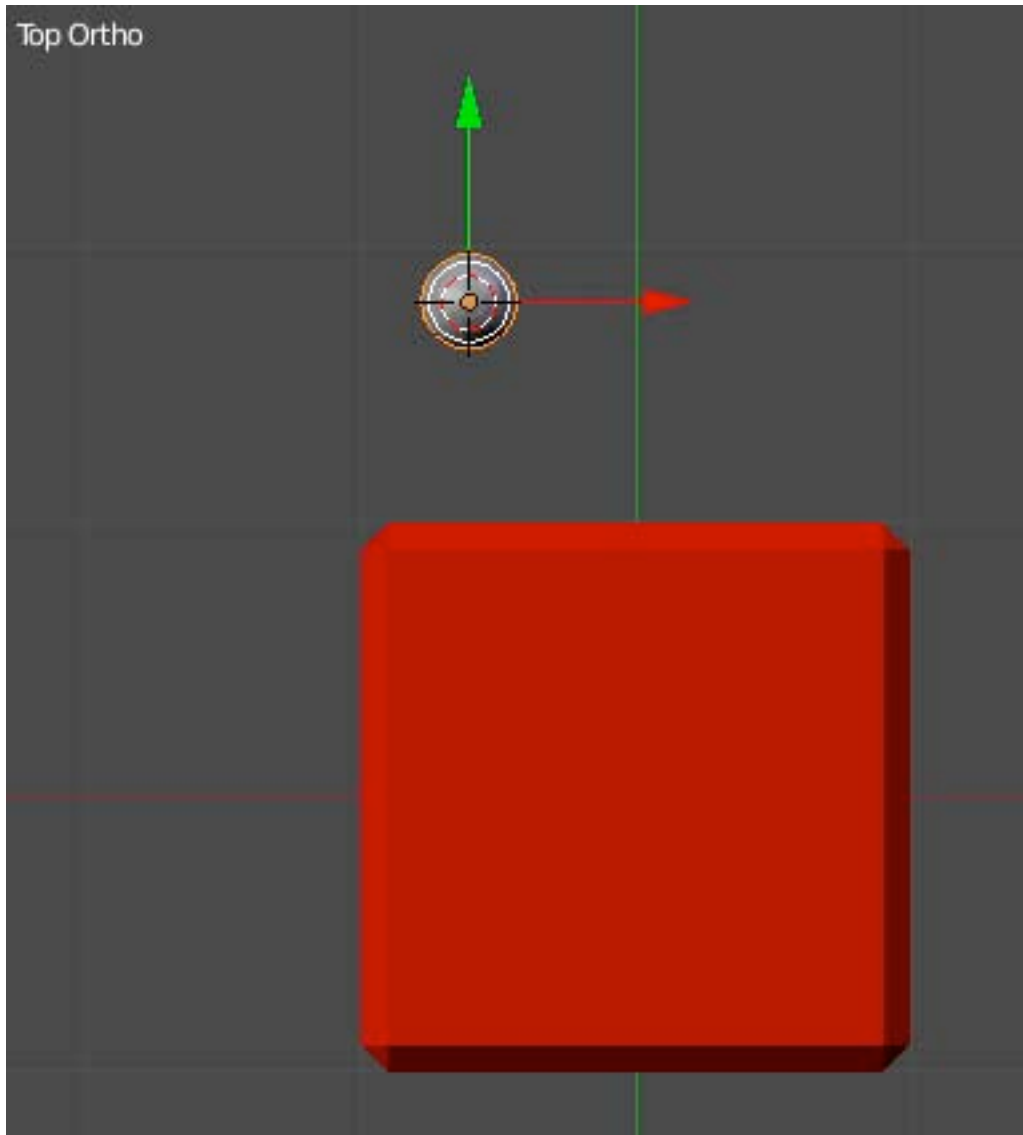

Name this object "Dot". With the Dot object selected, press the Smooth button located in the 3D editor tool panel.

Press the material context button in the properties panel and add a new material to the dot object. Name this material "Blue".

Click on the diffuse color swatch and make it a blue color (R=0, G=0, B=1).

Set the specular intensity to .75 and the hardness to 255. This will give the dot a more plastic appearance.

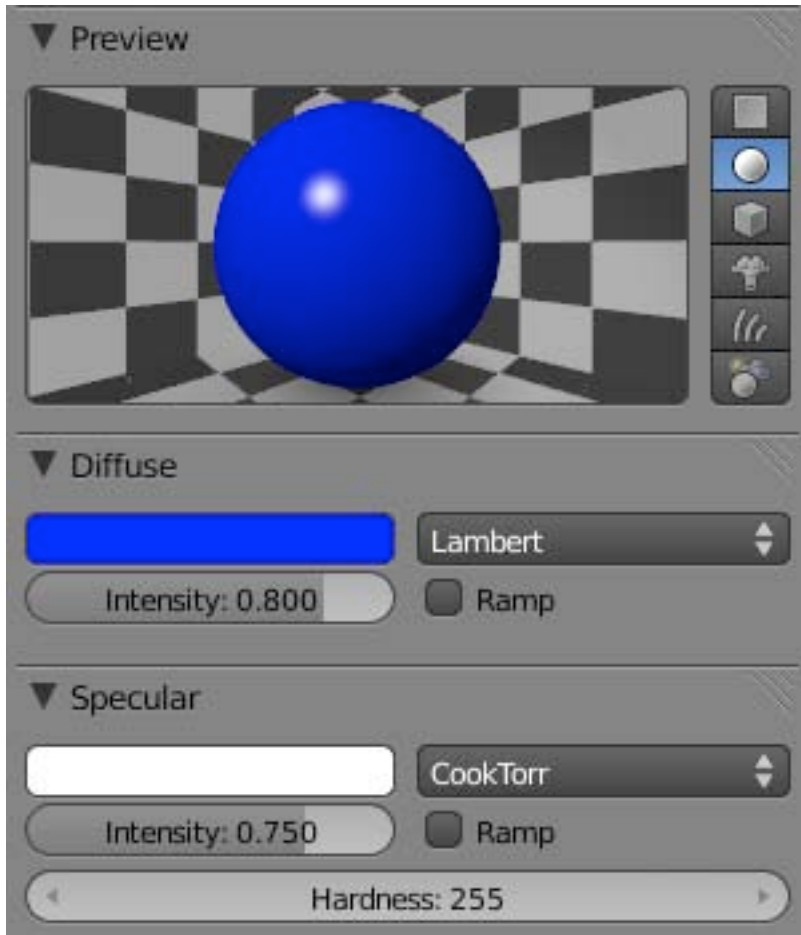

Press the modifier context button in the properties panel and add an Array modifier. Set the Relative offset to 1.5 and the count to 21

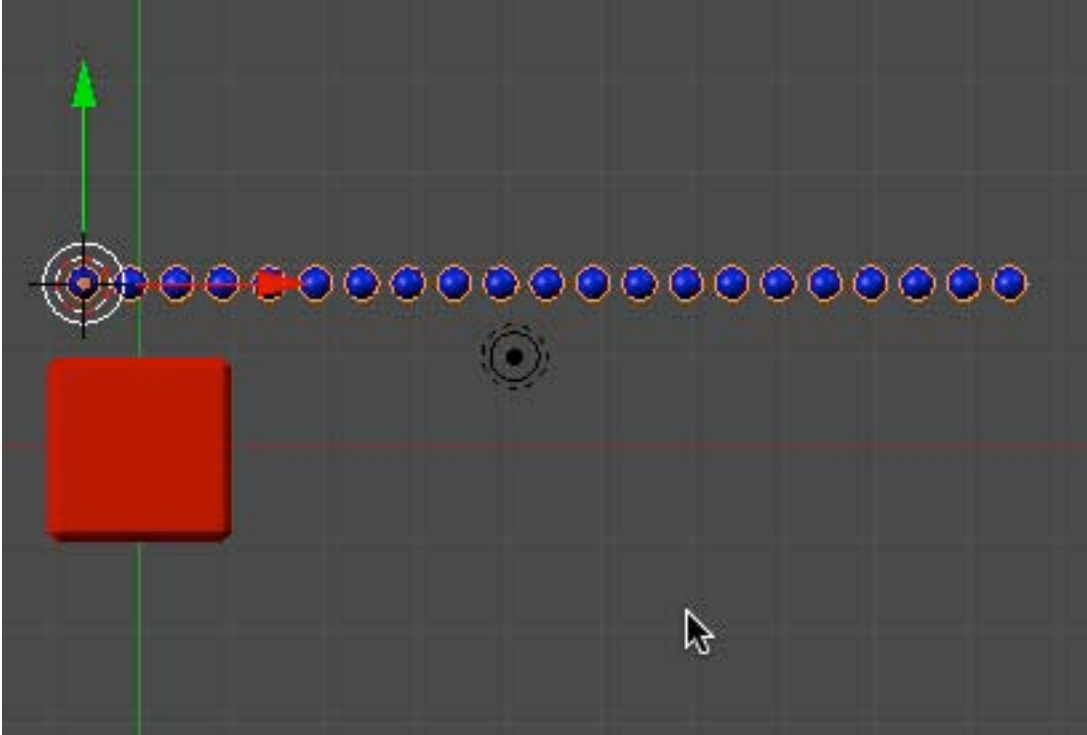

Next, **click on the APPLY button** in the array modifier panel. This will permanently apply the modifier and allow us to move each of the “dots” as an individual set of vertices.

Go to top view. TAB into edit mode. Deselect the vertices. Box select one of the dot set of vertices.

We need to place the dot vertices on the top face of the die object so that half of the vertices are in the die object and half of the vertices are out of the die object.

With the vertices selected, press the GKEY and move them to the center of the top of the die object.

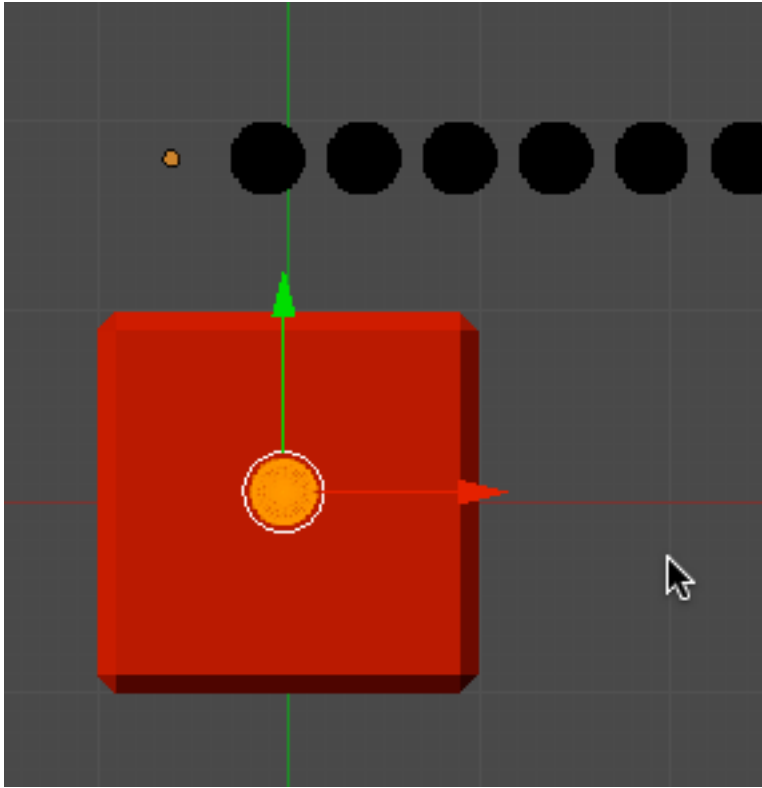

Go to front view. Make sure the dot vertices are half inside of the die and half outside as shown below.

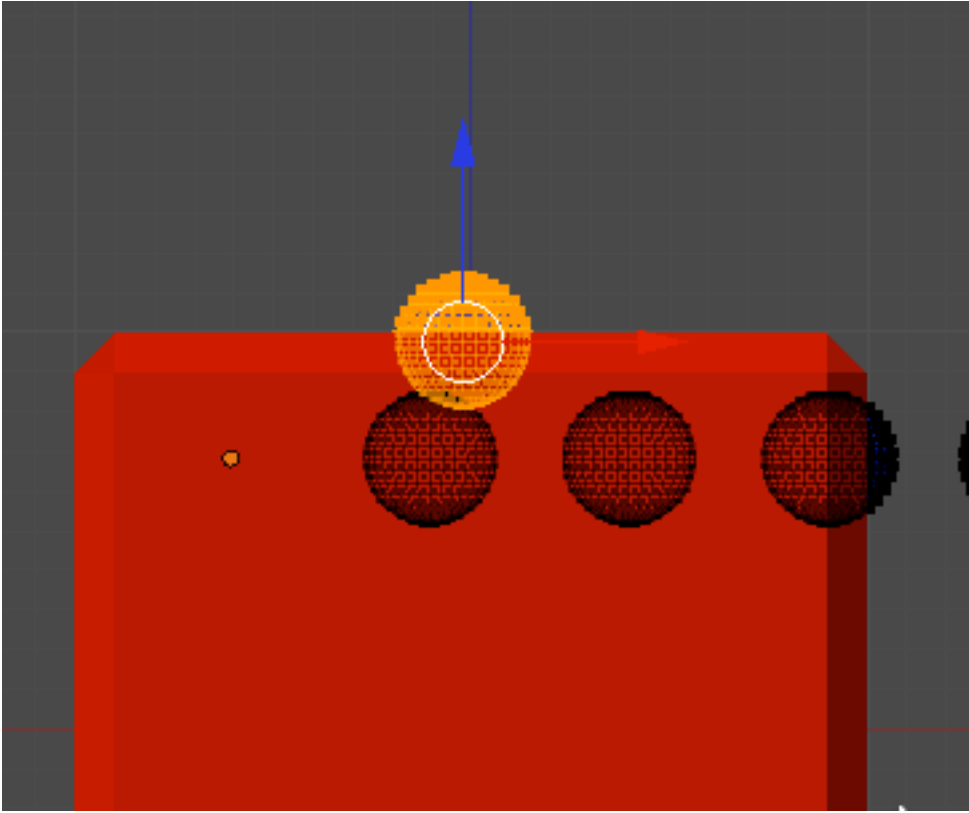

Go to side view. Your model should look as shown below.

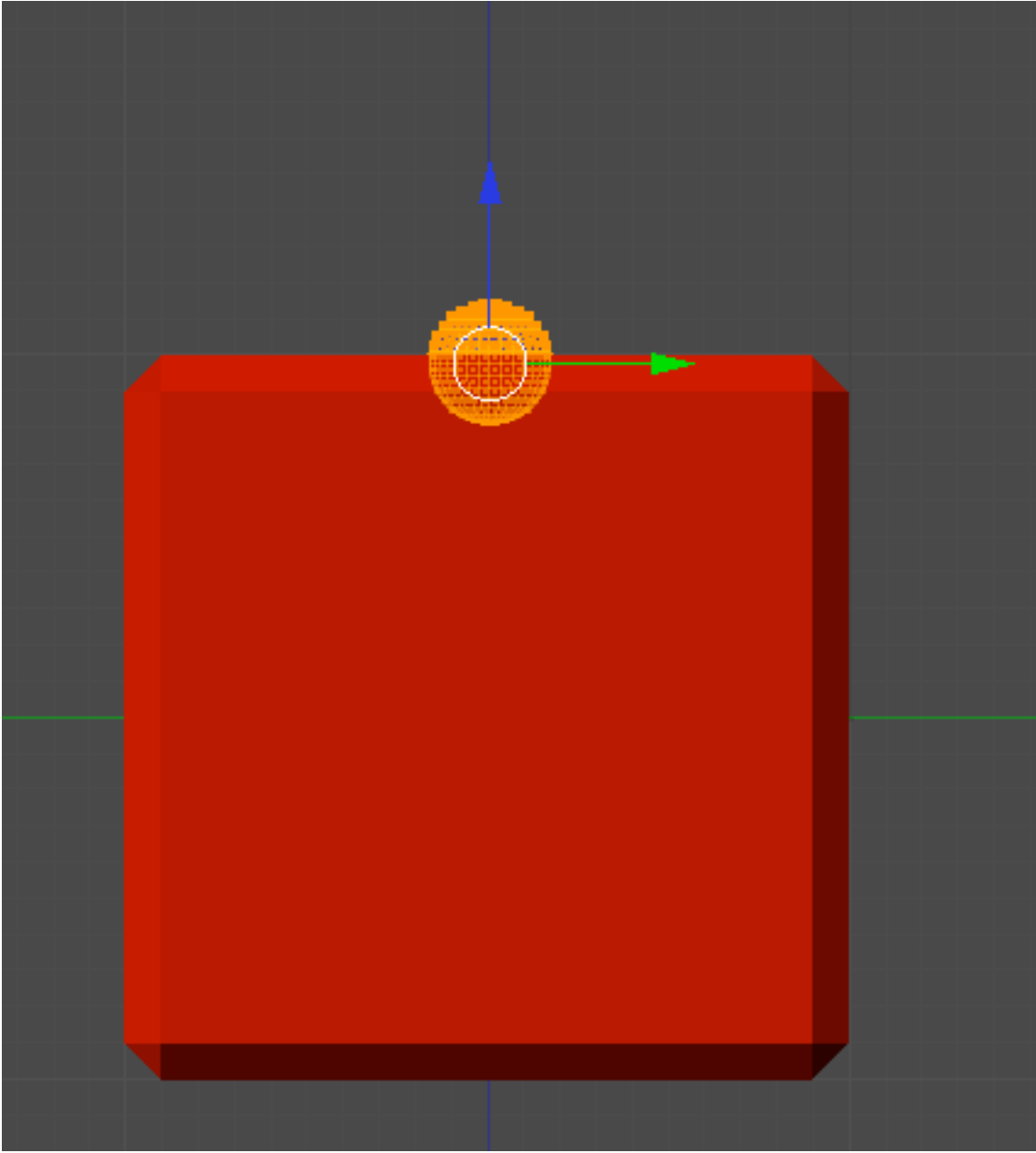

TAB out of edit mode. Your model should look as shown below.

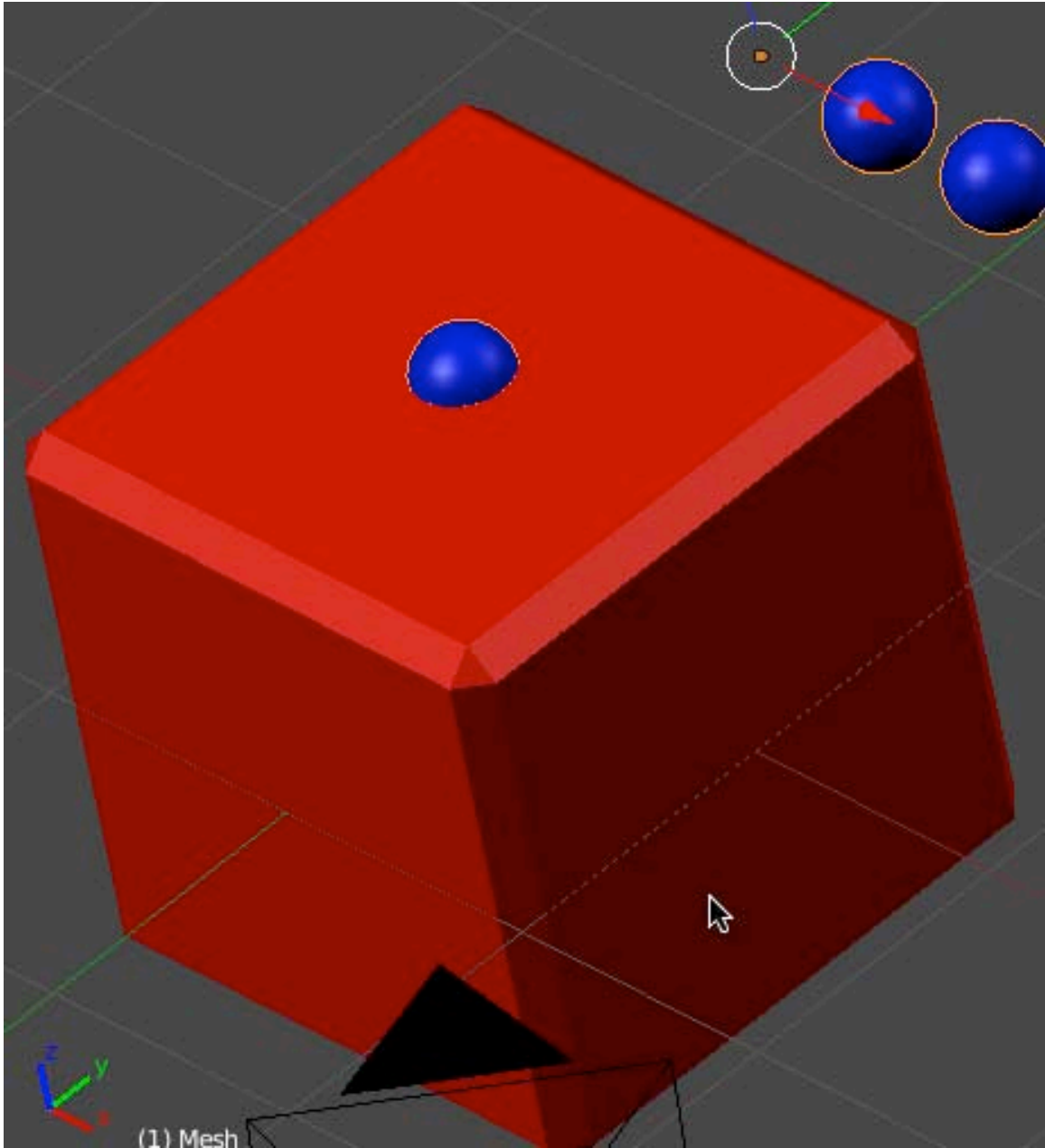

We need to repeat this same process placing 2 sets of dot vertices on the bottom (CTRL-NUMPAD-7) with the vertices half in and half out of the die object as shown below.

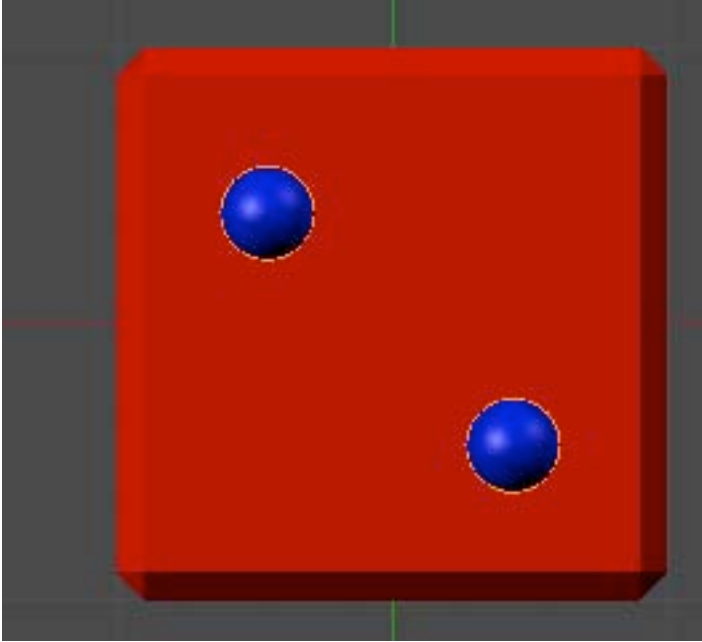

We need to repeat this same process placing 3 sets of dot vertices on the front with the vertices half in and half out of the die object as shown below.

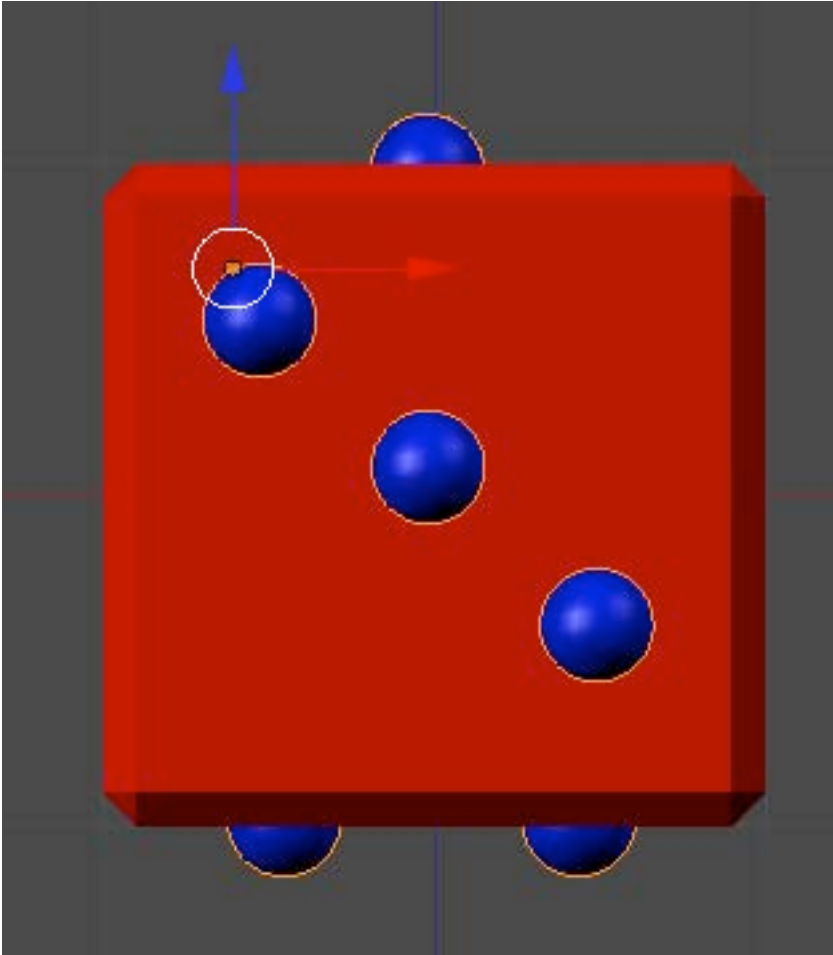

We need to repeat this same process placing 4 sets of dot vertices on the back (CTRL-NUMPAD-1) with the vertices half in and half out of the die object as shown below.

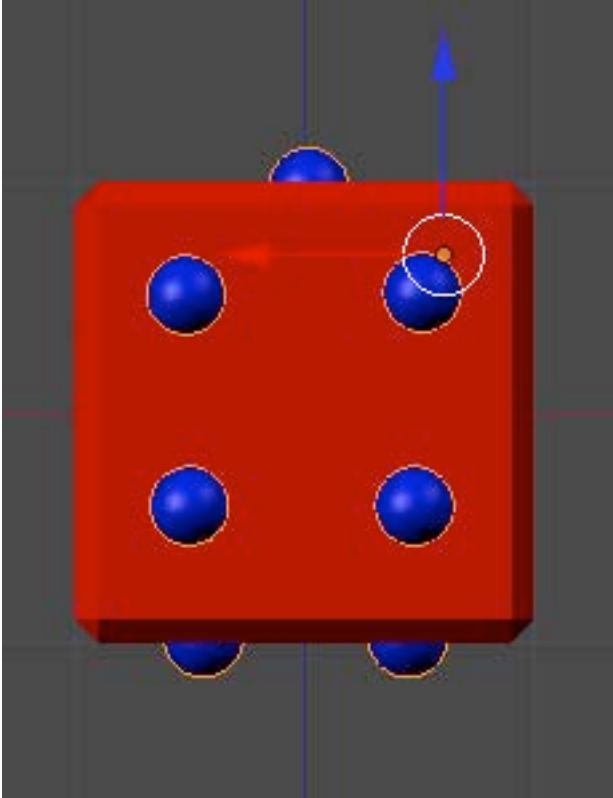

We need to repeat this same process placing 5 sets of dot vertices on the right with the vertices half in and half out of the die object as shown below.

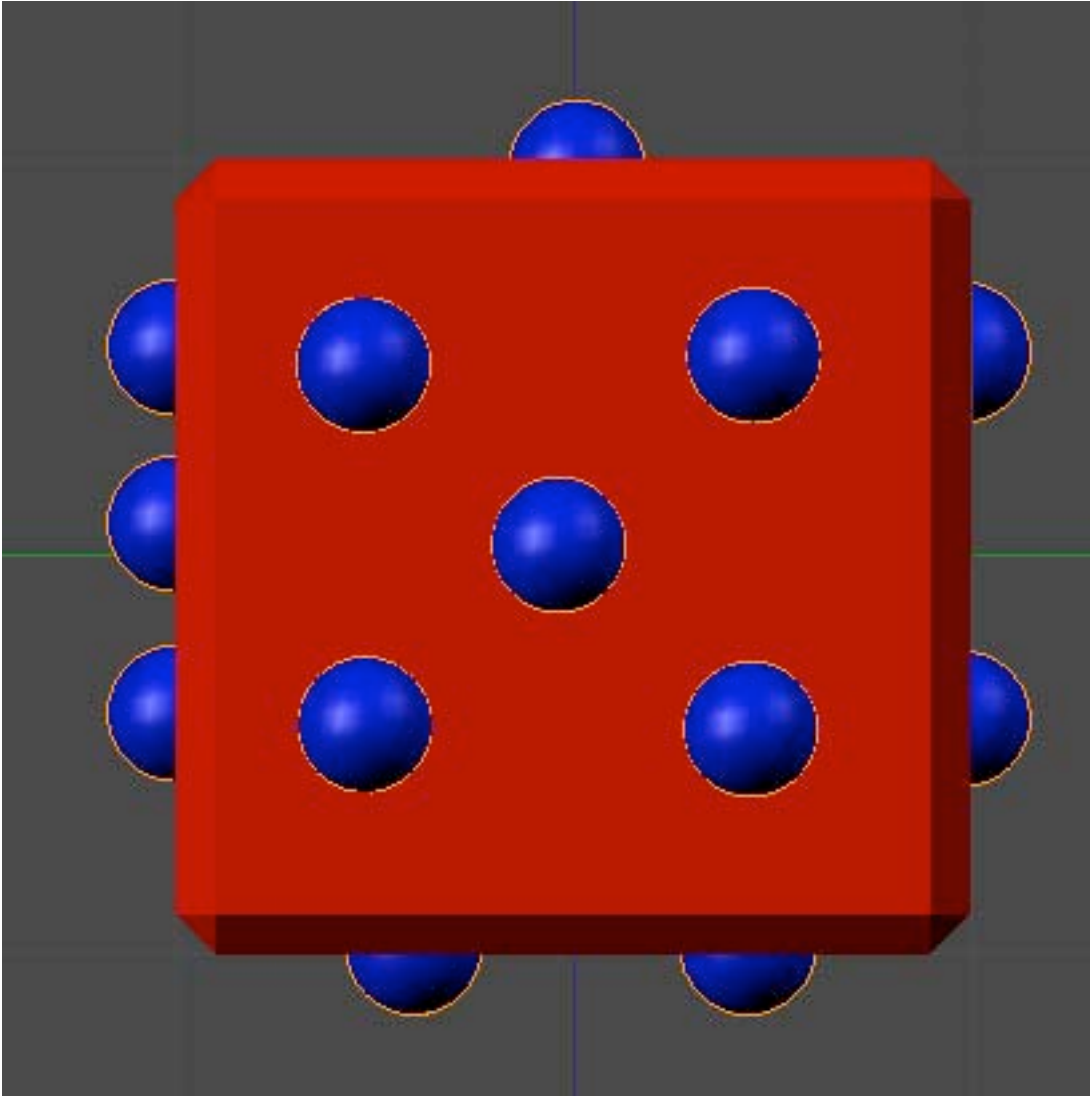

We need to repeat this same process placing 6 sets of dot vertices on the left (CTRL-NUMPAD-3) with the vertices half in and half out of the die object as shown below.

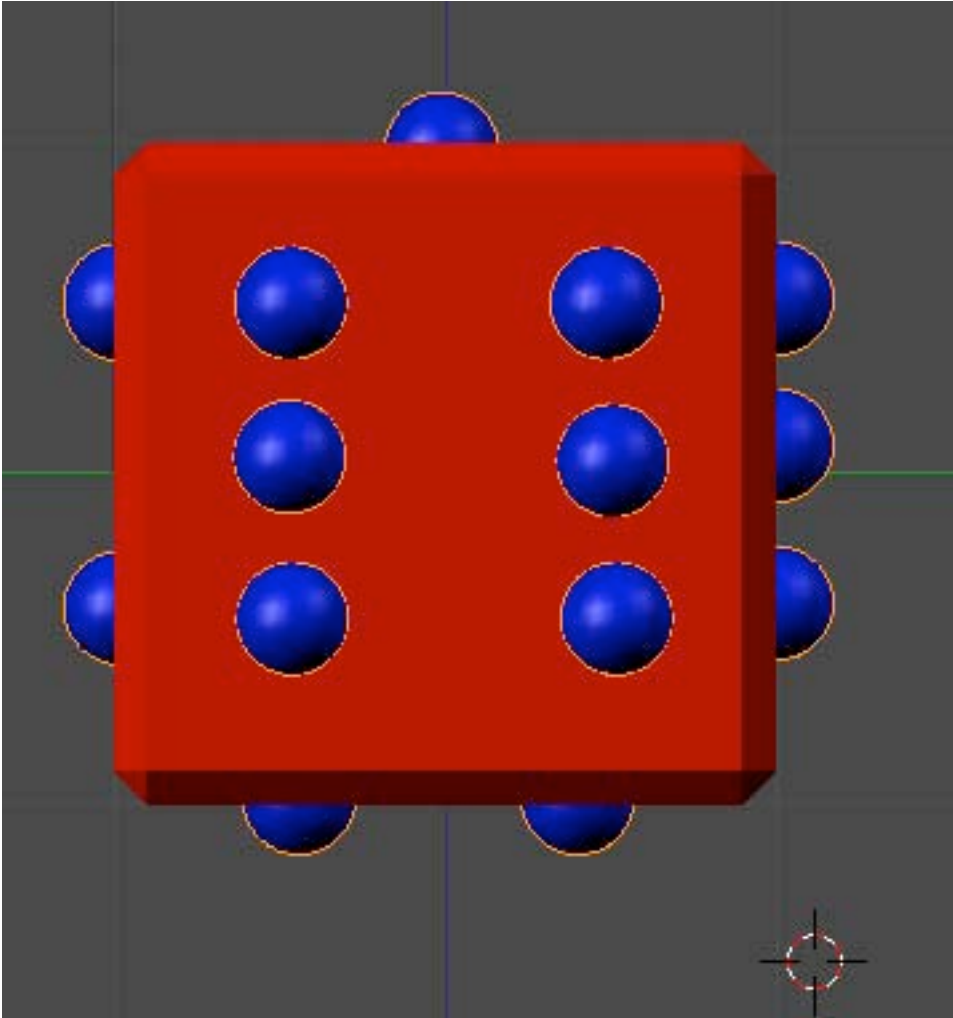

With the dot object selected and all of the dot sets of vertices in the right places press SHIFT-CTRL-ALT-C and set the **origin to the geometry**. This will place the center origin point in the center of the dot object geometry.

*** Save your Blender file.***

We are going to perform a Boolean operation called “Difference”. That is, we will subtract from the die1 object, the area occupied by the dot object leaving indented “dots” on the die. Boolean operations are generally CPU intensive. It is always a good idea to save your file before performing any Boolean operation.

Select the die1 object. Press the Modifier context button and add a Boolean modifier. Set the operation to Difference. Click on the object dropdown box and select the Dot object.



Depending on the speed of your CPU the Boolean operation may take awhile to complete.

Once the operation is complete, **Click on the apply button** in the modifier panel. This will apply the modifier and make it easier to move and transform the die1 object.

It might take some time for Blender to apply the Boolean modifier.

When it is complete, go to the Outliner editor and hide the Dot object and make it unselectable and un-renderable.

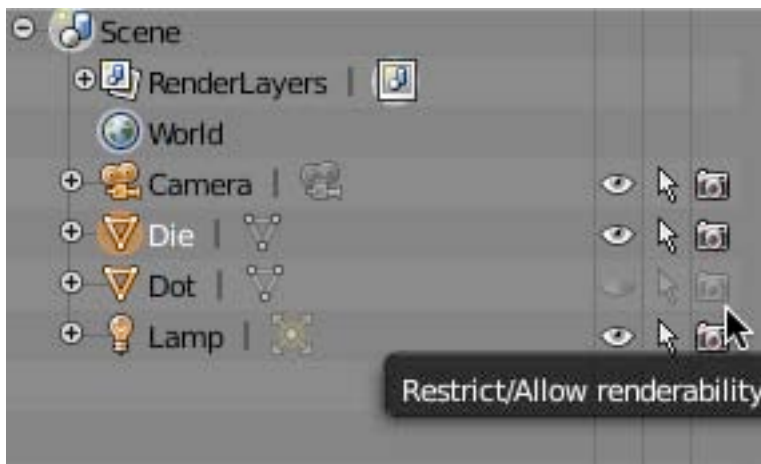

The Die1 object should now have the “dots” boleaned out of it.

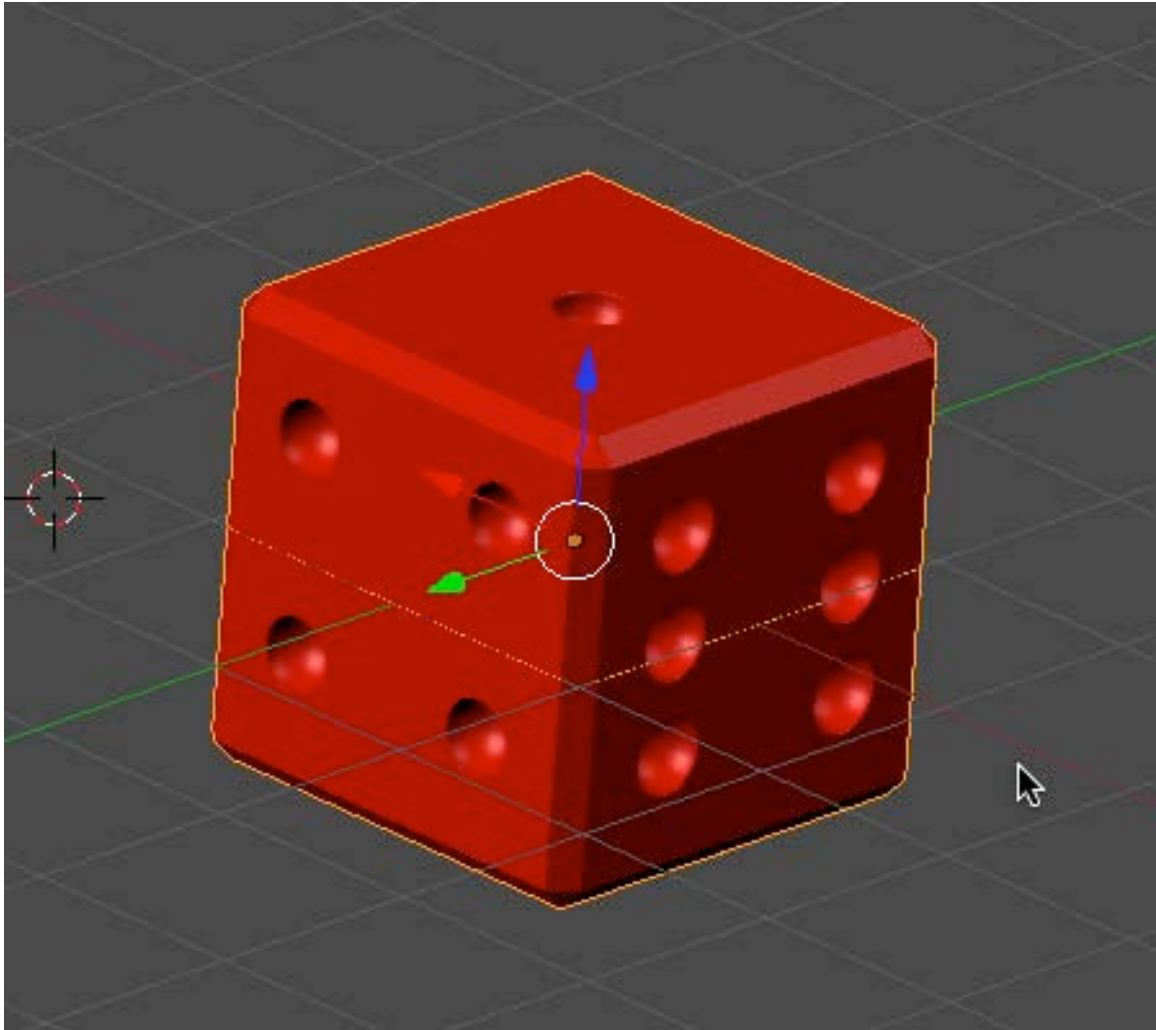

We now need to color the indented “dots”. Select the die1 object and go to the materials editor. Click on the Plus sign to the right of the materials list. This will create a second material (named Red).

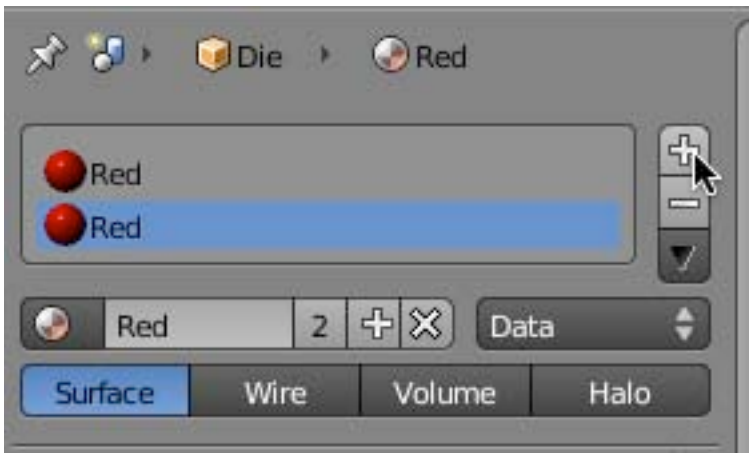

This second material is the same as the first. Notice that it has 2 users indicated by the number 2 in the box next to the material name. Click on this number (2). This will make the material independent of the first material and will rename it Red.001

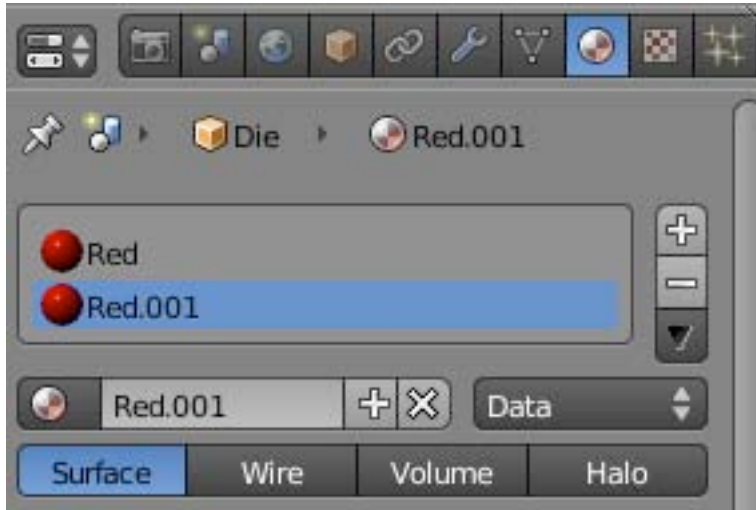

Click on the browse date ID dropdown box to the left of the Red.001 name and select the Blue Material we created earlier.

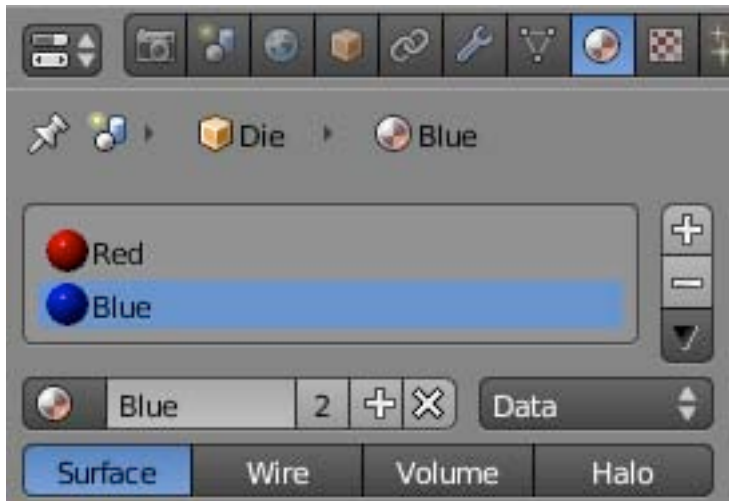

With the die1 object selected, TAB into edit mode **and deselect the faces**. Notice that there are now 3 new buttons in the material editor (assign, select, deselect).

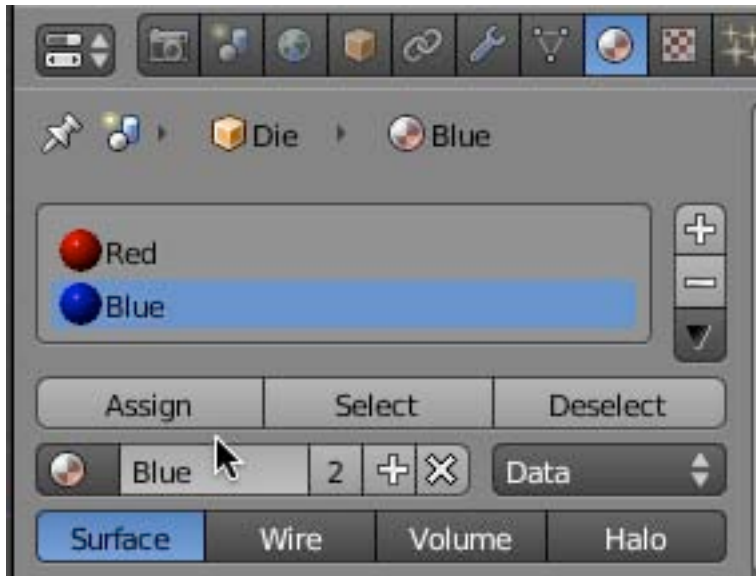

Select the Red material and then press the select button. Notice that all of the die1 object's faces are currently assigned to the red material.

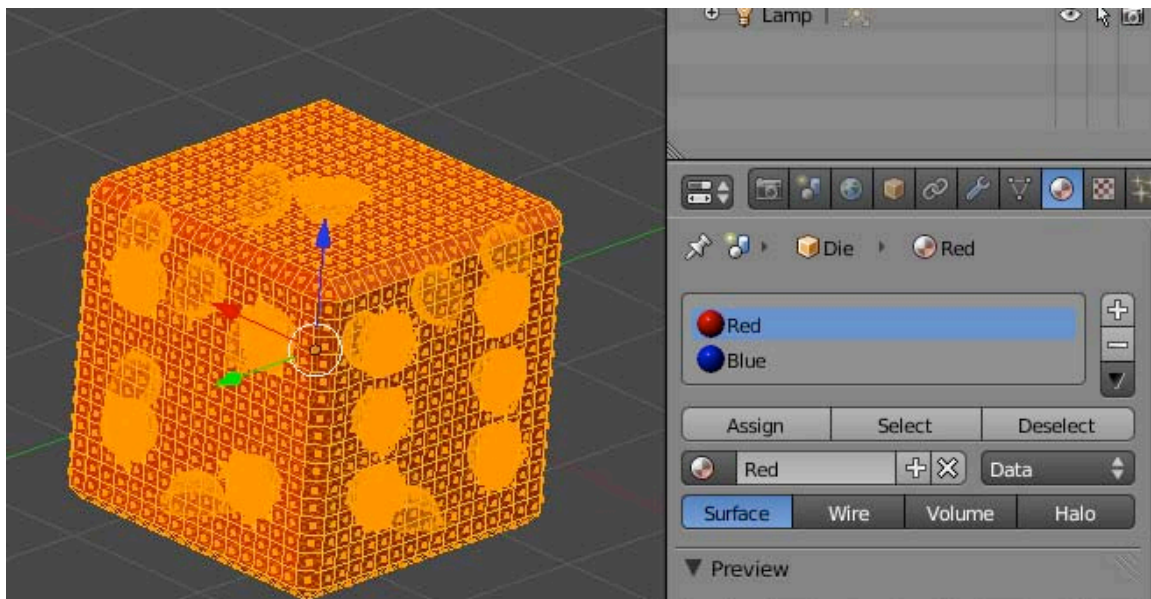

Press the deselect button.

We need to select all of the indented faces and assign them to the Blue color material.

Go to Front view. Go to wireframe display mode. Box select the faces on the left of the die1 object as shown below.

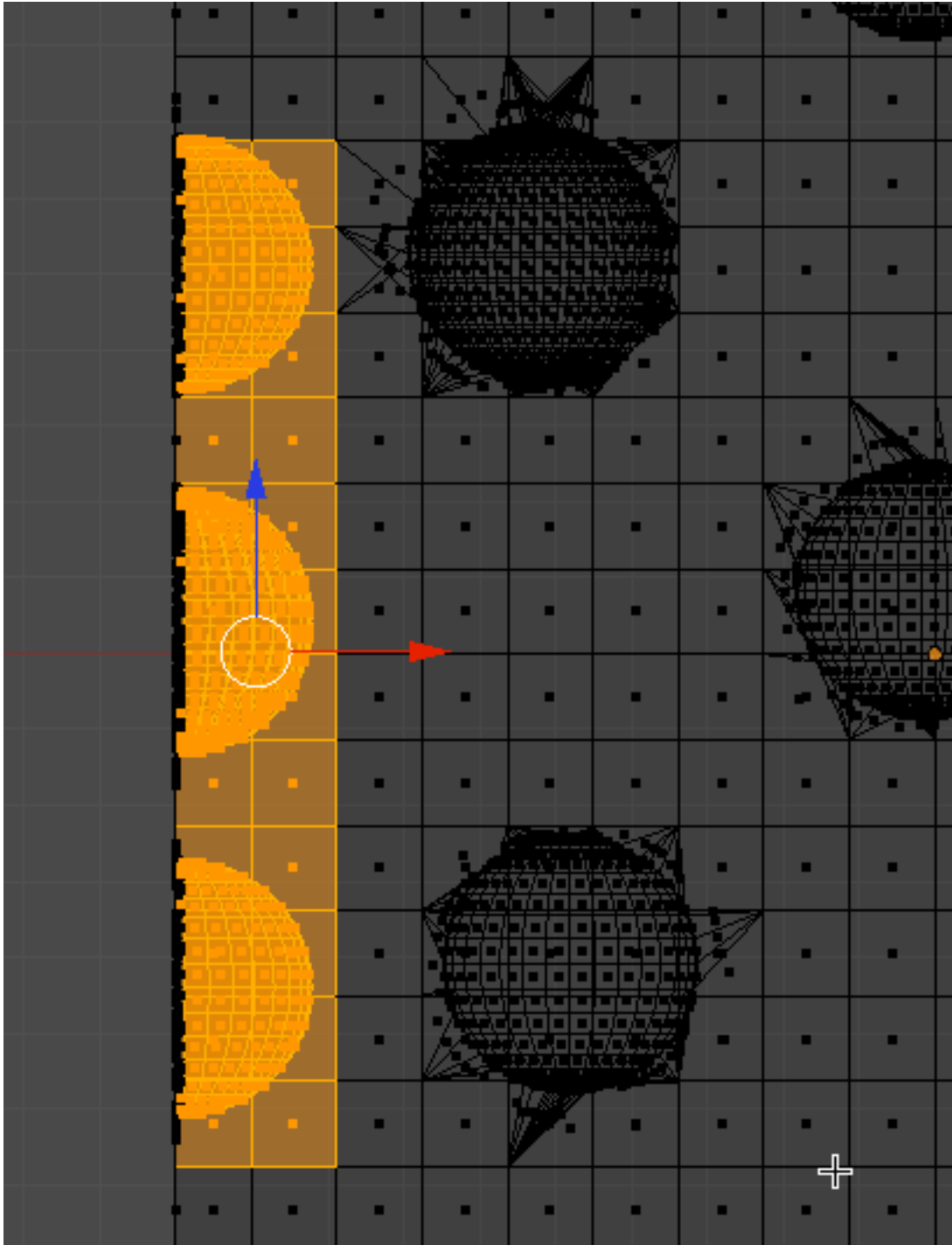

Press the BKEY again and do the same of the right side of the die1 object

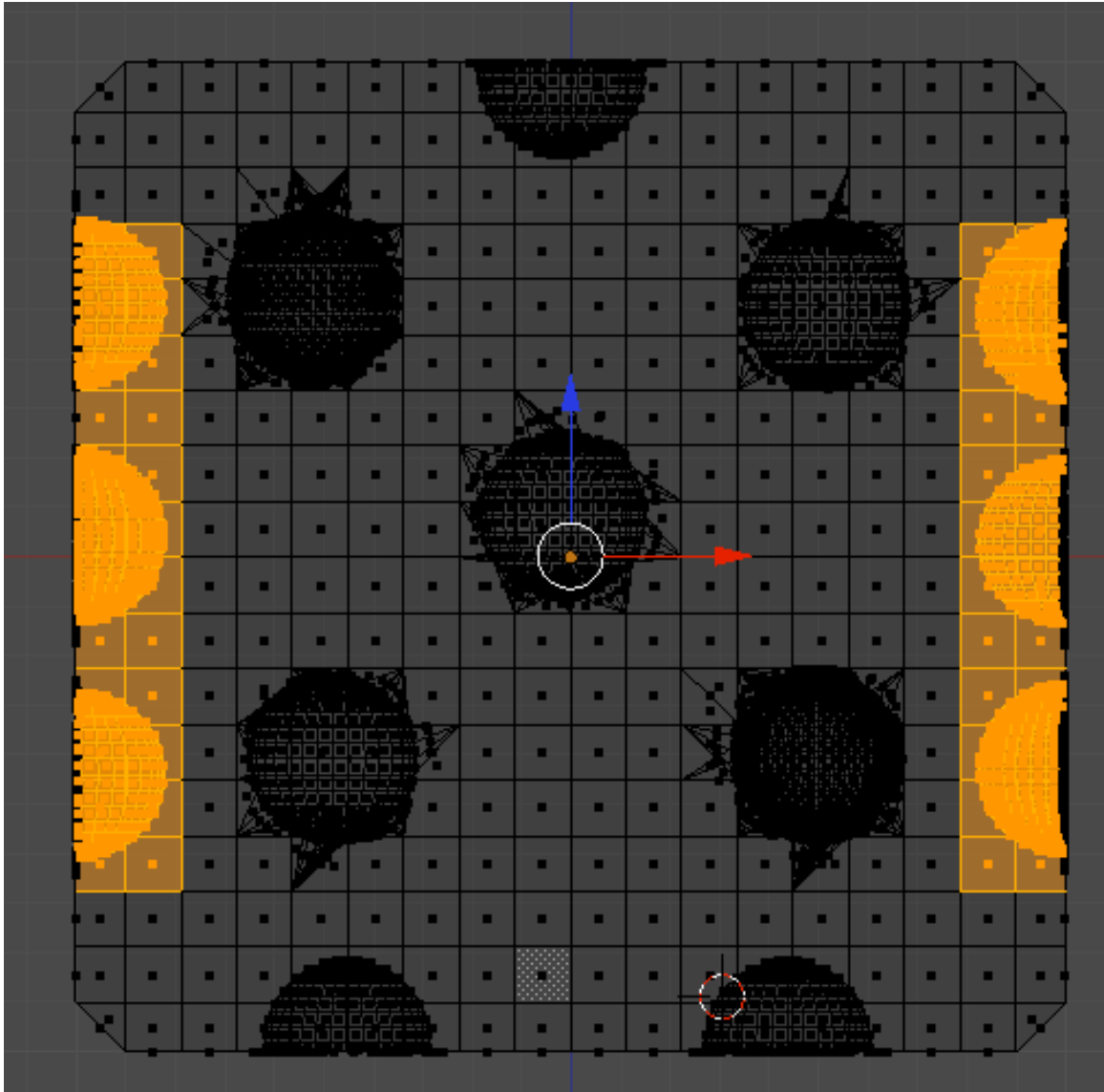

Do the same on the top and bottom.

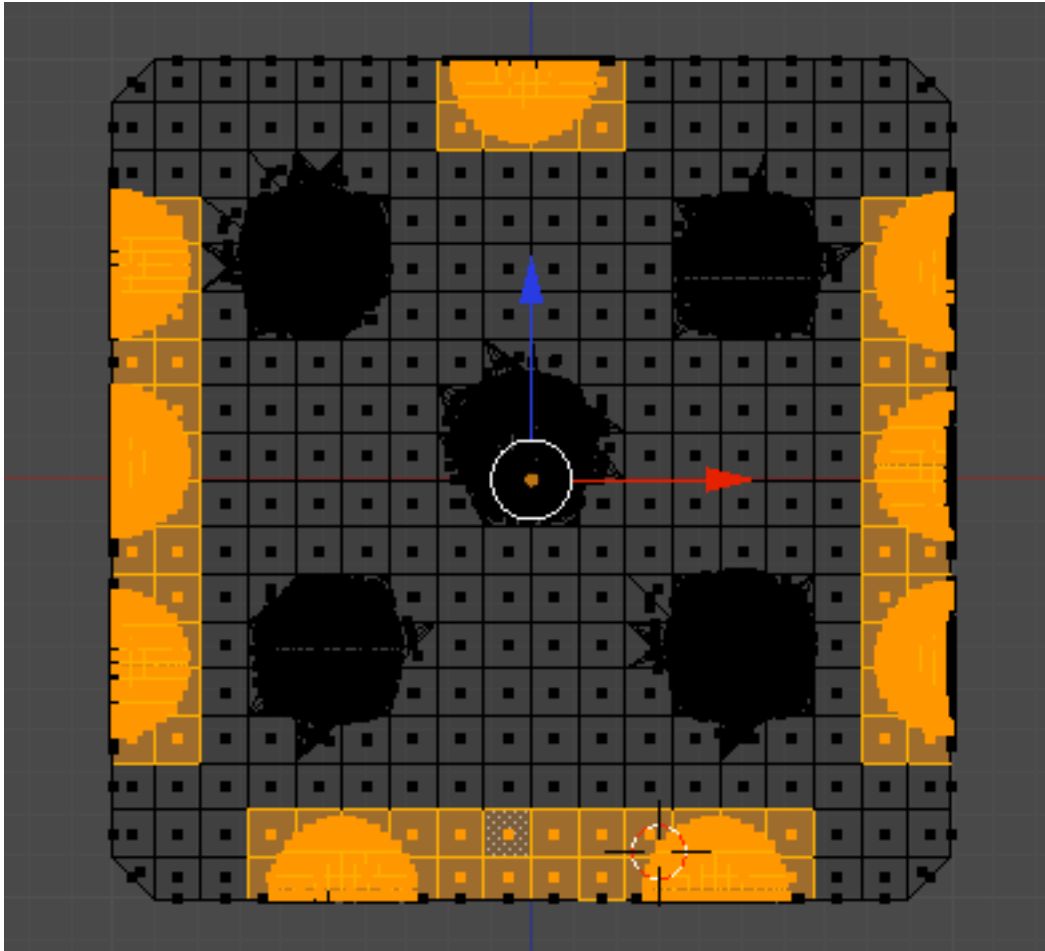

Go to side view and do the same on the left and right.

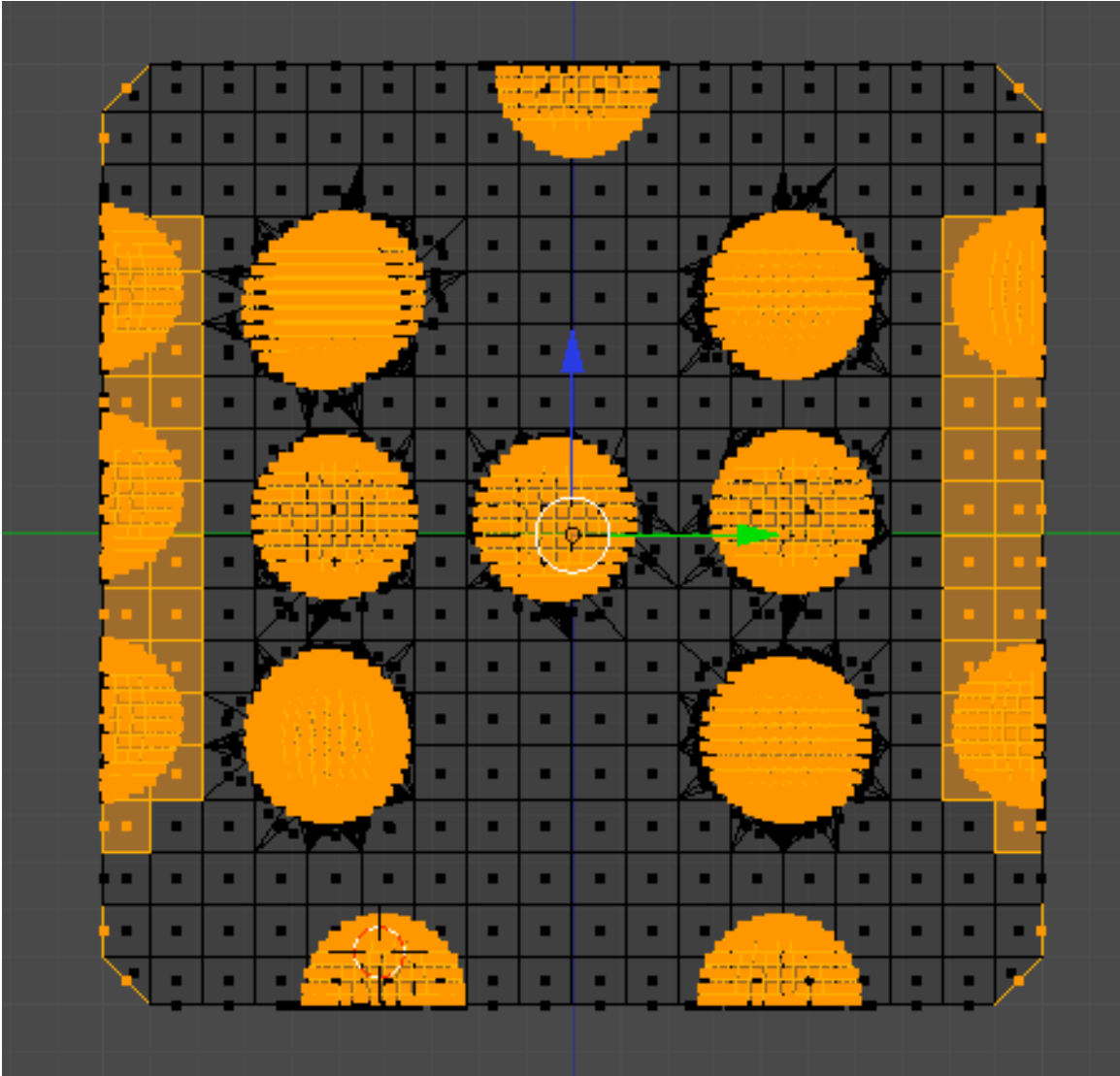

Now Go to solid display mode and press the “limit selection to visible” switch located on the 3D editor viewport header.

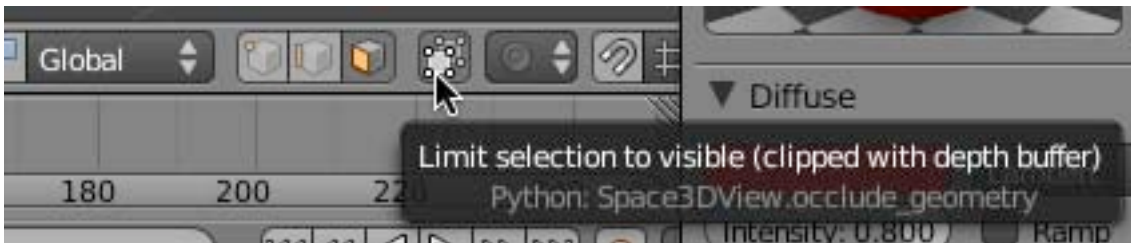

This will limit your selection to what is visible (will not select anything behind).

Hold down your SHIFT KEY and right-click n all of the faces that are selected that are not part of the “dots”. This will deselect them.

You should end up with all of the dot faces selected.

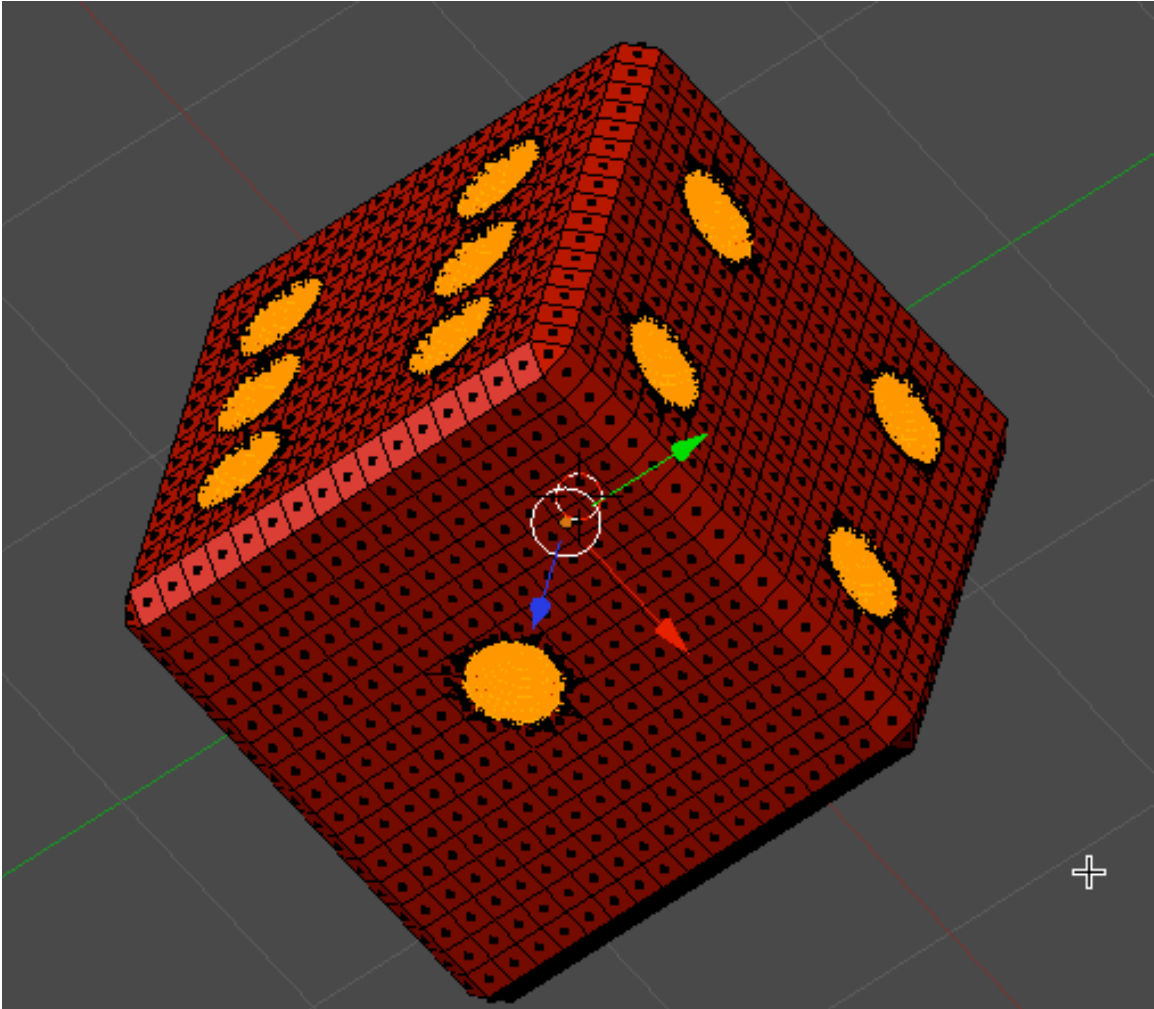

In the material editor, select the Blue material and then click on the assign button. This will assign the selected faces to the blue material.

TAB out of edit mode. The cube should now be red with blue indented dots.

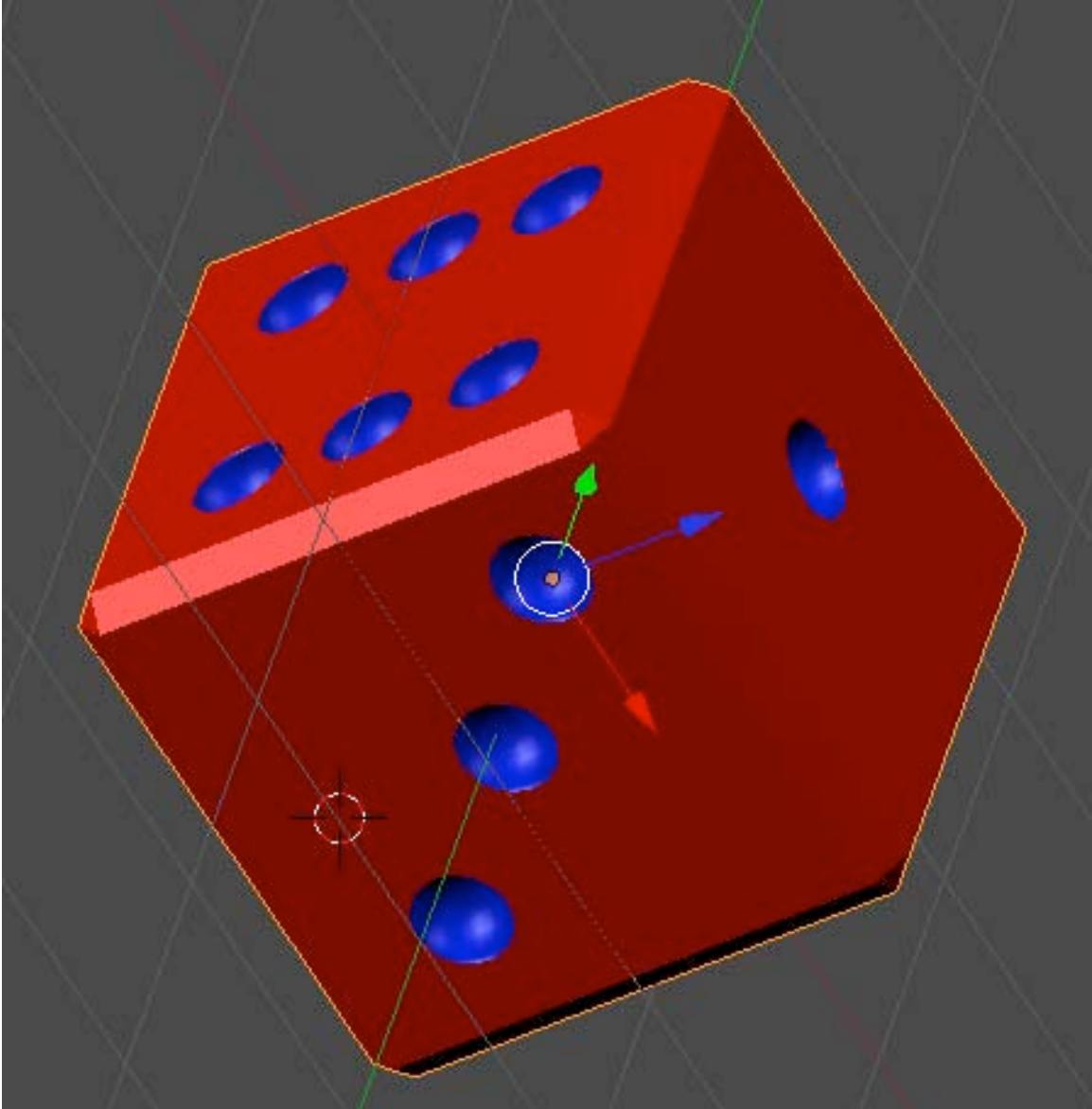

Save your Blender file.

Go to top view. Select the die1 object and press SHIFT-D and make a duplicate. Name this object "Die2".

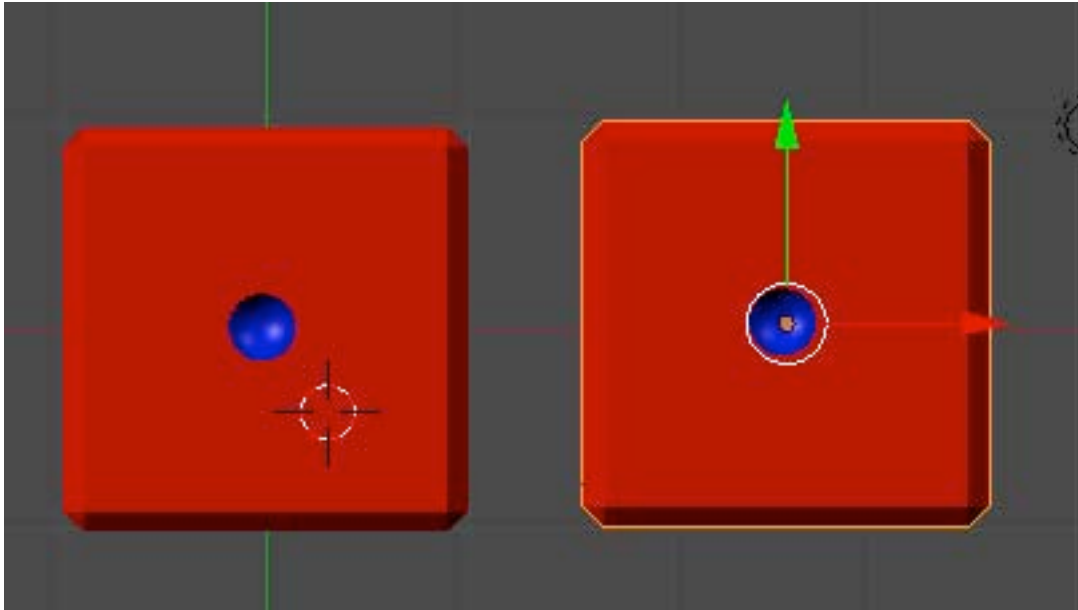

Rotate the die1 object 35 degrees around the Z Axis.

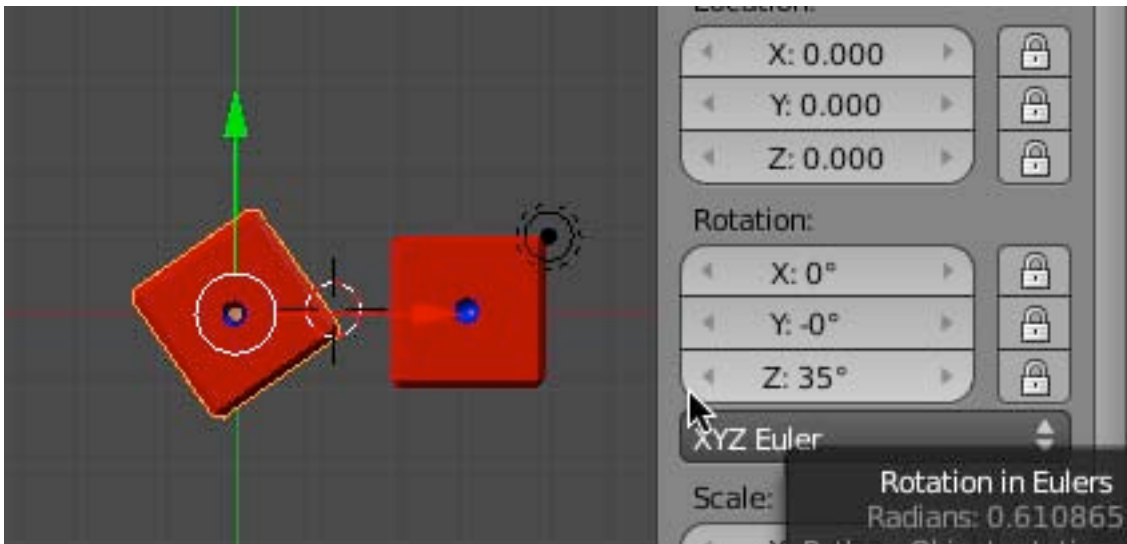

Rotate the die2 object 90 degrees around the X Axis, and -35 degrees around the Z Axis.

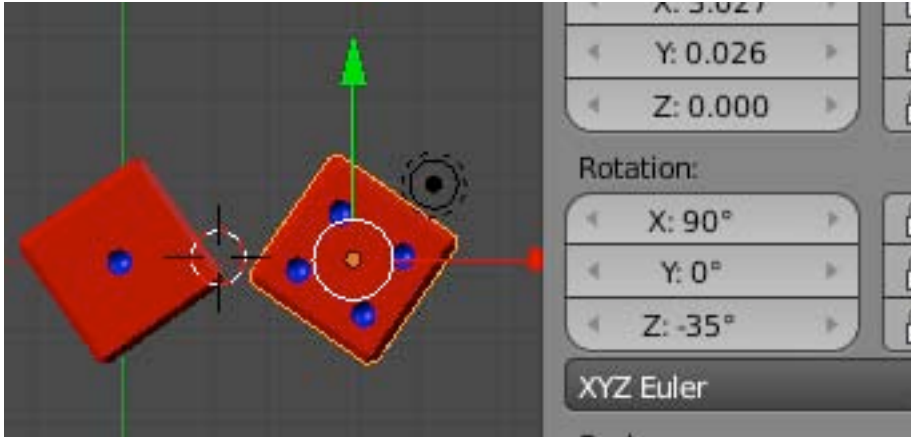

Go to top view. Place your 3D cursor in front of the dice and add an empty object. Name this empty object “Camera Focus Empty”.

Select the Camera object. Press the Constraint context icon and add a “Track To” constraint to the camera object.

Click in the Target box and select the Camera Focus Empty object as the target. Set the TO to $-Z$ and set the UP to Y

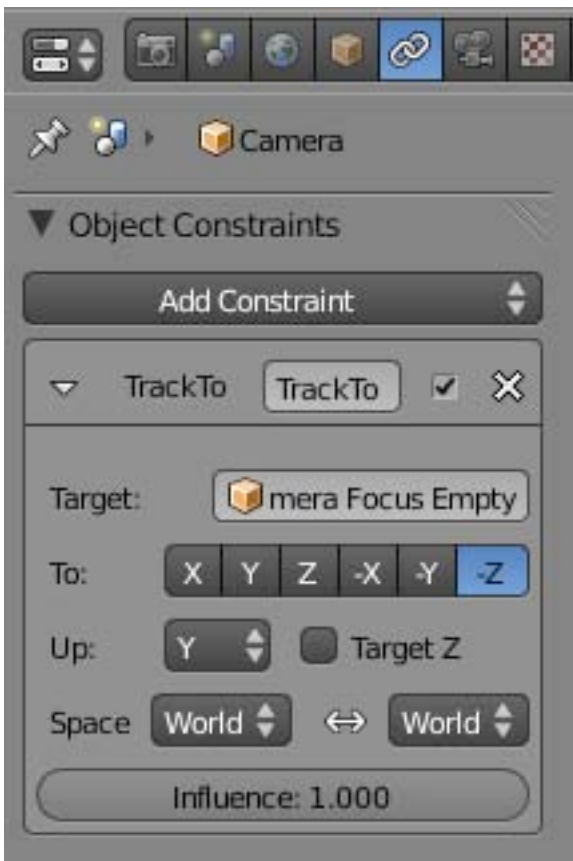

The camera is now constrained to the camera focus empty object and will always “look at” it. Place the camera focus object in the center of the dice.

Press CTRL-ALT-Q and go to quad view.

Adjust your camera and/or the camera focus empty so that the camera view look as shown below.

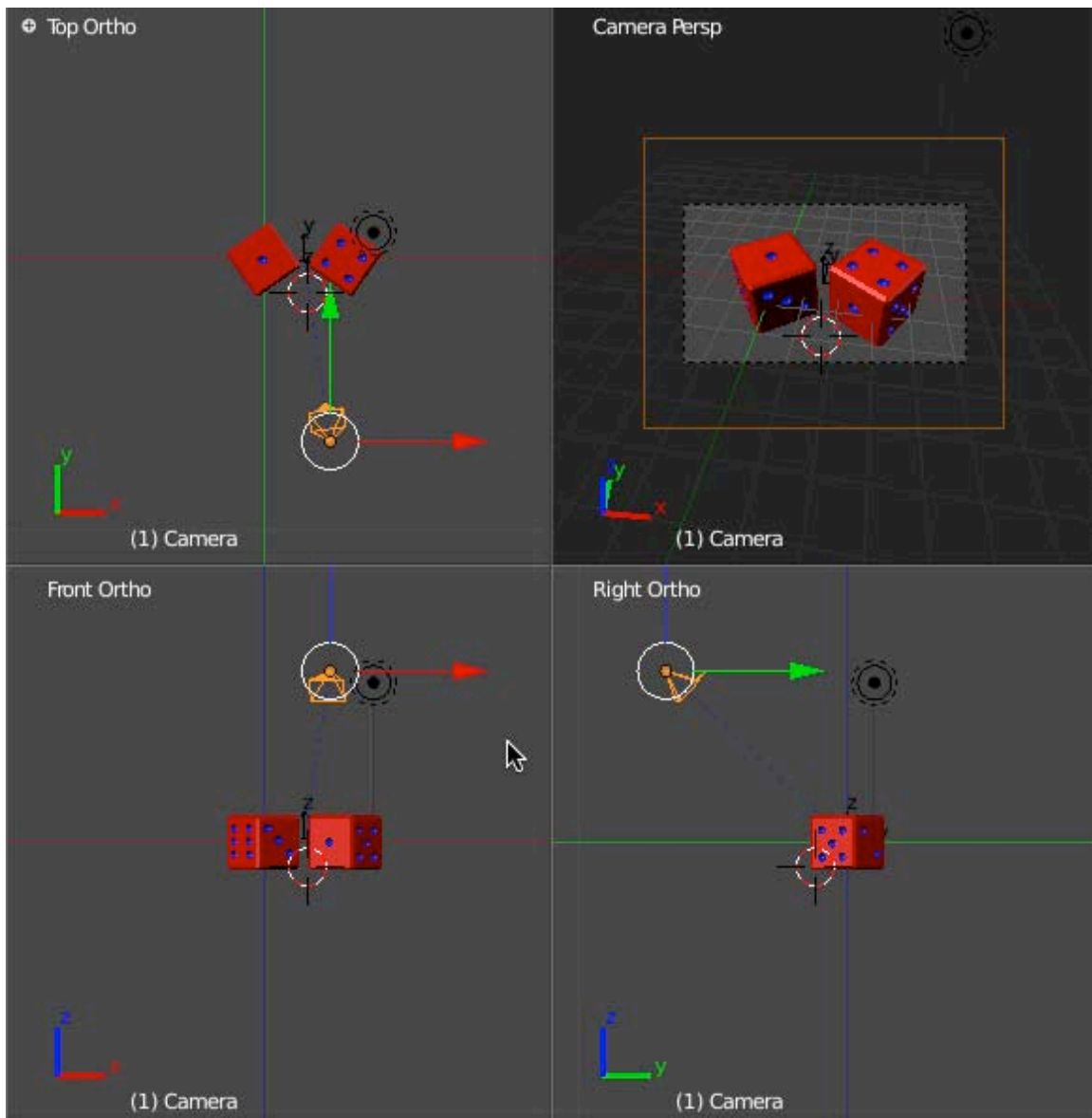

In the top view of the Quad, add a Hemi lamp as shown below.

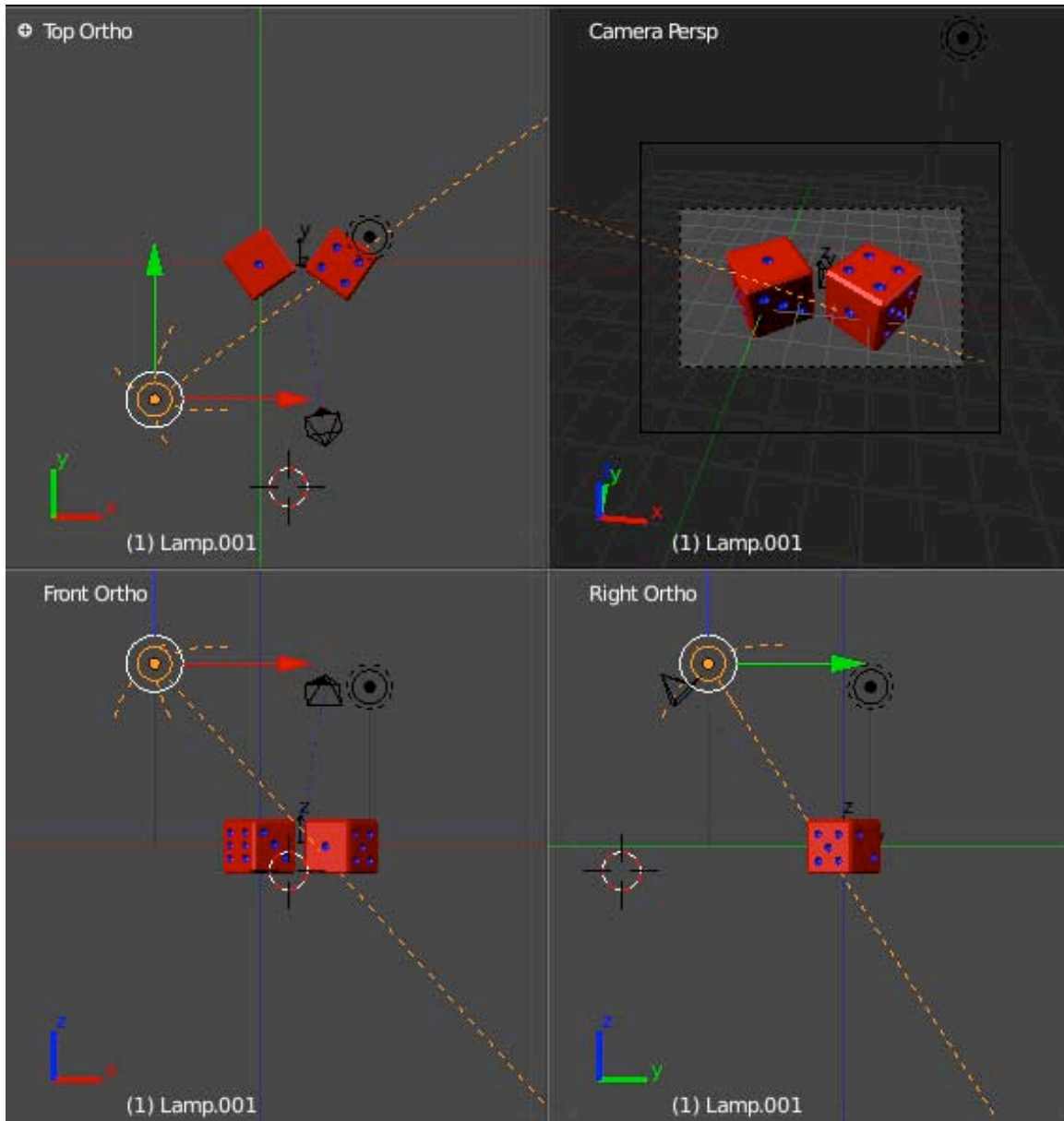

Render the scene (F-12).

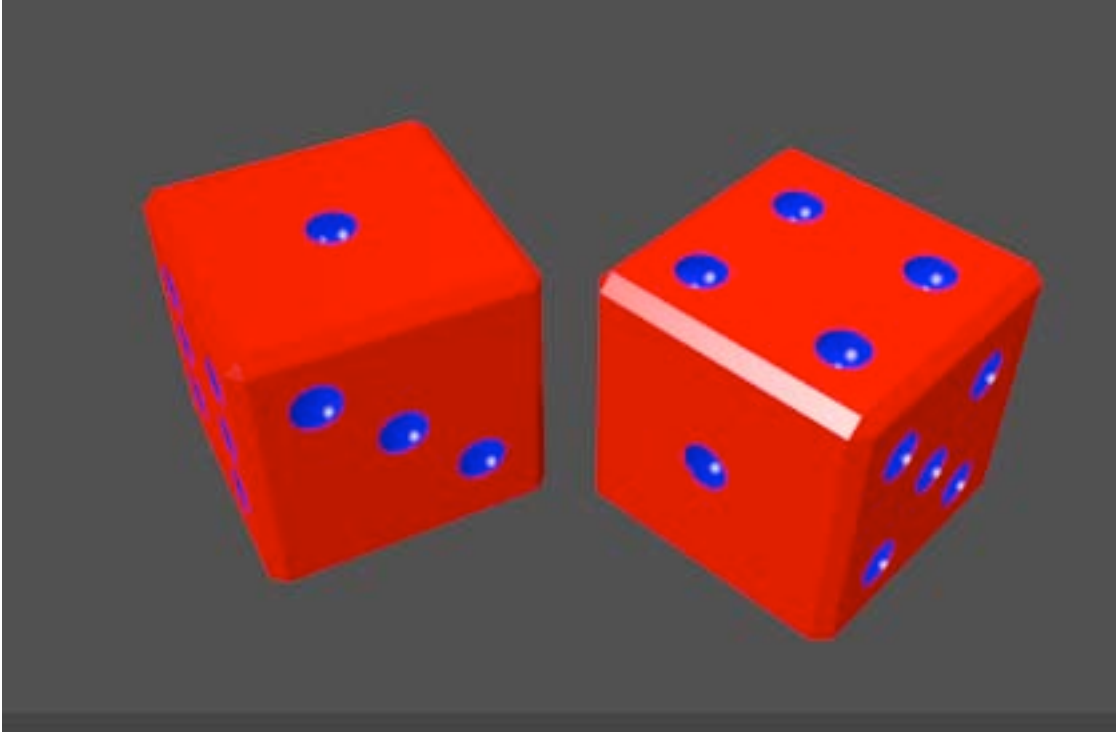

Save your Blender file.

A completed copy of this tutorial named DiceComplete.blend is located on our course site.